

Electric Wheel Loader HNL50EL

◆ Basic Parameter

Bucket capacity: (m^3)
 2.7-4.0
 Operating weight: (kg)
 5000
 Machine weight(kg) \approx 19200
 Max. Traction Force: (KN)
 155 \pm 3
 Max. Digging force (KN) $>$ 170
 Overall size: (L*W *H)
 8420*3000*3480
 Discharge Height: (mm)
 3062/3458
 Wheel Base: 3230
 Wheel Thread:(mm)
 2240
 Turning Angle: ($^\circ$)
 35
 Grade ability:($^\circ$) 28



ELECTRIC Wheel Loader

8 hours continuous operating in a single charge

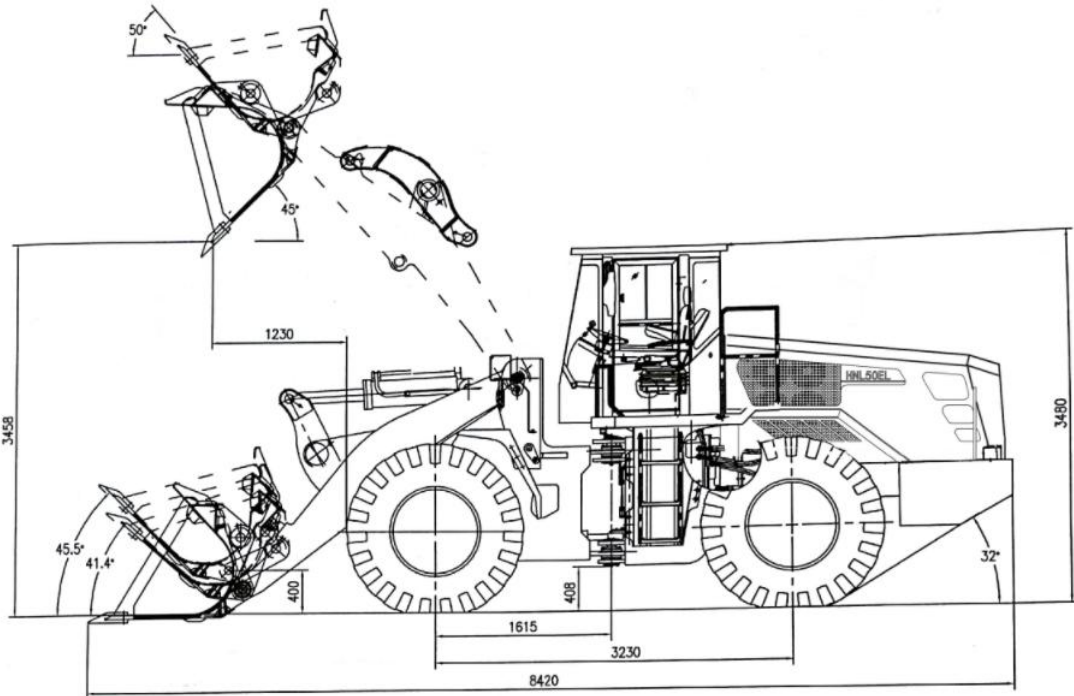

◆ Travel Speed (km/h) :

	Slow mode		High model	
	Gear1	Gear2	HG1	HG2
Forward (km/h)	7	14	30	57
Backward (km/h)	7	14	30	57

Battery power system :

Battery type:

Lithium Ironphosphate Battery

Temperature range of Working Climate:
(°C) 35-60

Thermir Management : Heating Film;
Water cooling

Rated power of storage:(kWh)141/282

Rated Current:(Ah)228/456

Recharging hours: Quick : 1.2-2.0hrs

/Standard:8-10 (subject to capacity of power supplier)

Recharging type: single gun charging or dual gun charging

Working Range of Voltage:(V)480-700

Cycling life 4000 次 , (25 °C , 100%SOC)

Capacity recession rate: <30%

Theoretical life > 8 years (25 °C , 100%SOC)

IP Rate: IP67



Driving Motor

- Travel Motor: Permanent Magnet Synchronous Motor (Rate: 100kw)
- Peak Rate :(kW)220
- Peak Torque: 2500N.m@60s
- Rate Voltage: 540V

Transmission System:

- Electronic Shifting Transmission 2F/2R
- Pressure in the Gearbox (Mpa) 1.3-1.6
- Main drive spiral bevel gear one reduction
- Wheel edge reduction type straight tooth cylindrical gear planetary transmission

Tires Size: 23.5-25-16PR



Brake System

- Service Brake : Hydraulic Clamp Disc
- Parking Brake
- Hydraulic Oil(Mpa) 12-14

Steering Hydraulic System

- Full hydraulic load sensing steering system
- Pressure (Mpa) 15
- Steering Angle: ±35 °



Email: alex@socmachinery.com Tel:+865925650662

Operating Hydraulic System

Hydraulic Pump Motor

Motor type:Permanent Magnet Synchronous Motor

Rated Power: *90 kw*

Peak Power : *180kw*

Peak Torque: *2000N.m@60s*

System pressure:*16 Mpa*



Email: alex@socmachinery.com Tel: +865925650662

各种油品容量

液压油 (L) 270

变速箱 (L) 49

前桥/后桥 (L) 28/28